

GREASE COLLECTOR

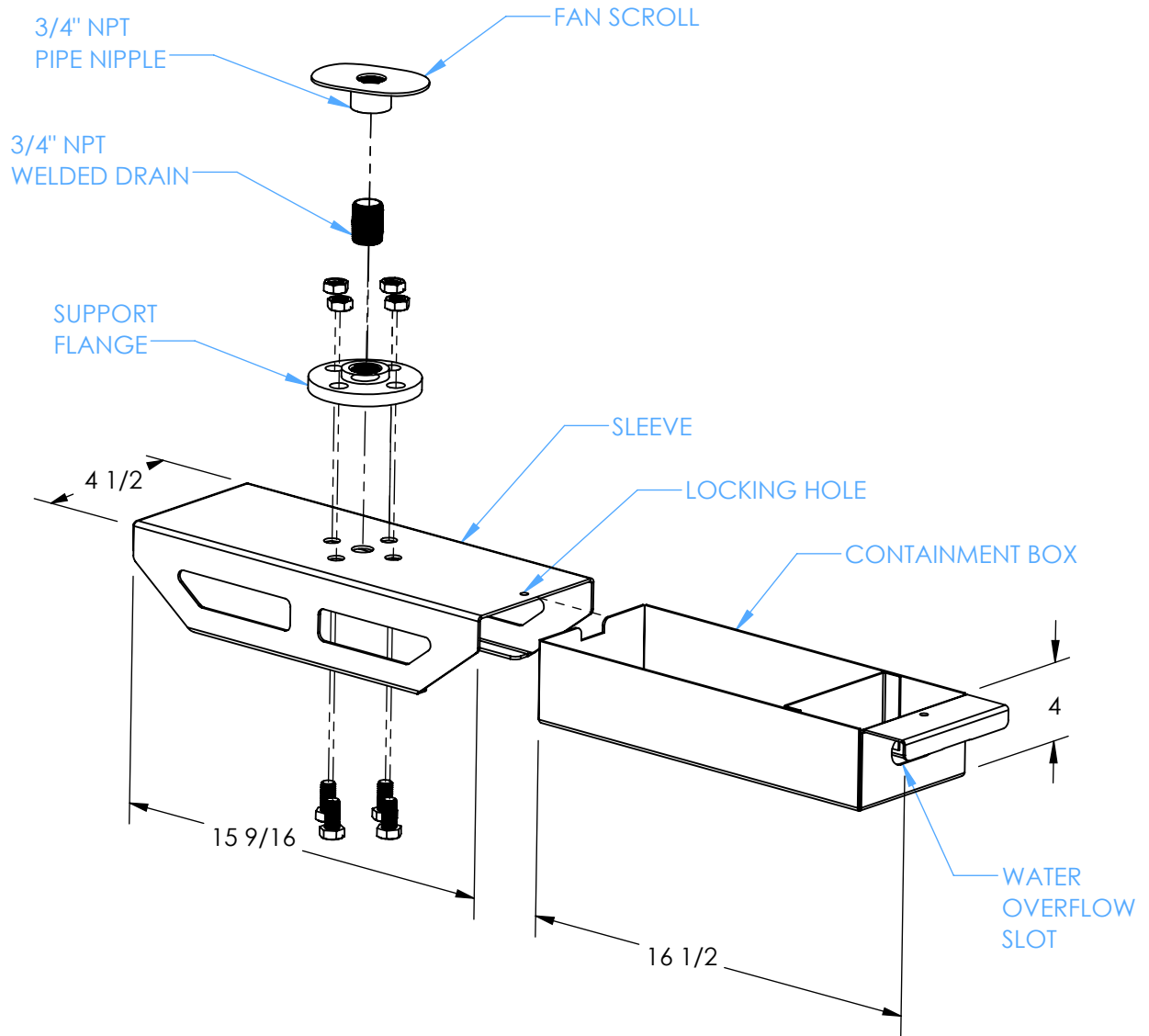

NOTES

1. Aluminum and welded construction
2. Box designed to contain grease on one side and drain water thru overflow slot
3. Containment box slides out from sleeve for ease of servicing
4. Can be supplied with optional Absorbent Sock (not shown)
5. Approximate assembly weight = 6 lbs. (box only = 3lbs.)
6. See IOM for additional details

ALL DIMENSIONS ARE IN INCHES